

GNDL

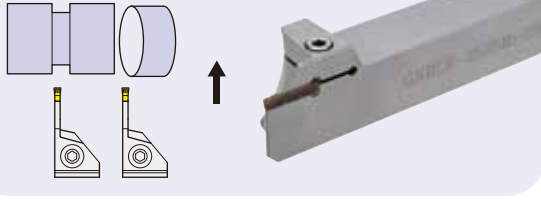

功能：開槽 Grooving / 切斷 Cut-off

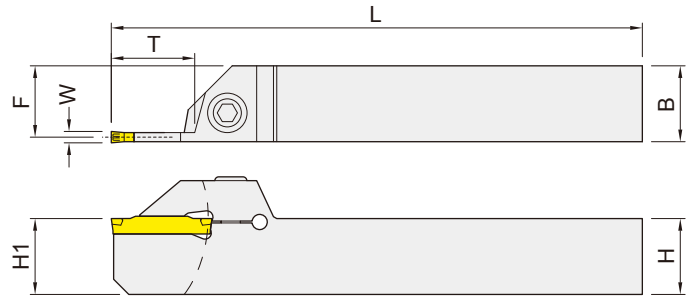

Right-hand shown

Item code	Dimensions,mm					Width W(mm)	Insert	Screw	Wrench	Weight Kg
	H(H1)	B	L	F	T					
GNDLR-2020K-220T	20	20	125	19.2	20	2.0	GCMN20...	HTMT525	ETL25	0.45
GNDLR-2525M-220T	25	25	150	24.2						0.84
GNDLR-1616K-320T	16	16	125	14.9	20	3.0	GCMN30...	HTMT520	ETL25	0.24
GNDLR-2020K-320T	20	20	125	18.9						0.45
GNDLR-2525M-320T	25	25	150	23.9	20	4.0	GCMN40...	HTMT525	ETL25	0.84
GNDLR-2020K-420T	20	20	125	18.5						0.45
GNDLR-2020K-425T	20	20	125	18.5	25				ETL25	0.45
GNDLR-2525M-425T	25	25	150	23.5						0.84

GNDL..LH

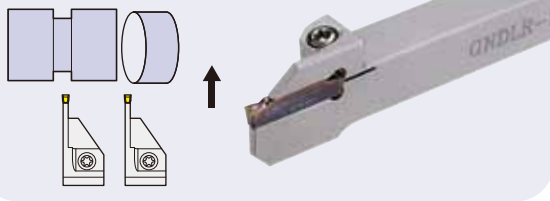

功能：開槽 Grooving / 切斷 Cut-off

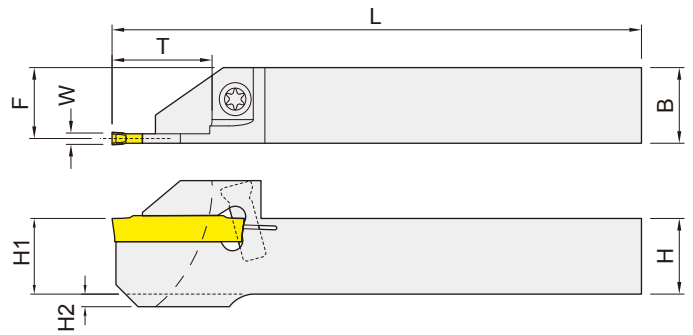

Right-hand shown

Item code	Dimensions,mm							Width W(mm)	Insert	Screw	Wrench	Weight Kg
	H(H1)	B	L	F	T	H2						
GNDLR/L-1212K-216LHT	12	12	125	11.25	16	2	2.0	GCMN20...	MS4013F	ETL15	0.15	
GNDLR/L-1616K-216LHT	16	16	125	15.25	16	--					0.24	
GNDLR/L-1212K-318LHT	12	12	125	10.95	18	2	3.0	GCMN30...			0.15	

※走心式刀 SWISS-TYPE

※刀片請參考 101 頁 See page 101 for insert.

BORING BARS 內徑車刀
 TOOLHOLDERS 外徑車刀
 THREADING & GROOVING 牙刀 & 開槽刀
 MILLING 銑刀
 BORING TOOLS COMPONENTS 孔加工
 SPARE PARTS 配件

NEW

BORING BARS
內徑車刀

TOOLHOLDERS
外徑車刀





THREADING & GROOVING
牙刀 & 開槽刀

MILLING
銑刀

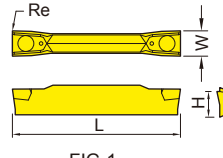
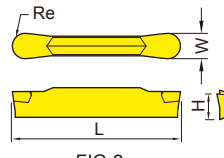
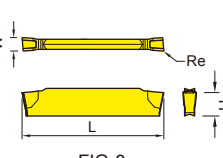
BORING TOOLS COMPONENTS
孔加工

SPARE PARTS
配件

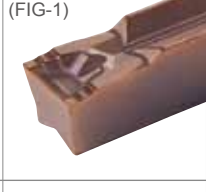
Insert Shape		Steel 鋼	P	●	●	
		Stainless steel 不銹鋼	M	●	●	
		Cast iron 鑄鐵	K	●		●
		Non-ferrous metal 非鐵金屬	N			

屑槽樣式 Breaker Name	Description	Dimensions, mm					GRADE 材質			
		W	L	H	Re	K	Coated 塗層			
							AC530U	AC830P	AC425K	
多機能 (泛用型) For Multifunctional Grooving (General Purpose)		GCMN3004-MG	3	21.1	3.8	0.4	--	●		●
		GCMN4008-MG	4	26.4	4.0	0.8	--	●		●
		GCMN5008-MG	5	26.4	4.1	0.8	--	●		●
		GCMN6008-MG	6	26.4	4.5	0.8	--		●	●
多機能 (低送型) For Multifunctional Grooving (Low feed)		GCMN3002-ML	3	21.1	3.8	0.2	--	○		●
		GCMN4004-ML	4	26.4	4.0	0.4	--	●		●
		GCMN5004-ML	5	26.4	4.1	0.4	--	●		
		GCMN6004-ML	6	26.4	4.5	0.4	--			●
仿型 (泛用型) For Profiling (General Purpose)		GCMN3015-RG	3	21.1	3.8	1.5	--	●		
		GCMN4020-RG	4	26.4	4.0	2.0	--	●		
		GCMN5025-RG	5	27.2	4.1	2.5	--	●		
		GCMN6030-RG	6	27.5	4.5	3.0	--			
切斷 ● 切槽 (泛用型) For Grooving / Cut-off (General Purpose)		GCMN2002-GG	2	21.1	3.6	0.2	--	●		
		GCMN3004-GG	3	21.1	3.8	0.4	--			
		GCMN4004-GG	4	26.4	4.0	0.4	--		●	
		GCMN5004-GG	5	26.4	4.1	0.4	--			
切斷 ● 切槽 (低抵抗) For Grooving / Cut-off (Low Cutting Force)		GCMN3002-GF	3	21.1	3.8	0.2	--	○		
		GCMN4002-GF	4	26.4	4.0	0.2	--	○		
		GCMN5002-GF	5	26.4	4.1	0.2	--	○		
		GCMN6002-GF	6	26.4	4.5	0.2	--	●		
切斷 ● 切槽 (切斷) Grooving / Cut-off		GCMR/L2002-CG05	2	21.1	3.6	0.2	5°	●		
		GCMR/L3002-CG05	3	21.3	3.8	0.2	5°	○		
		GCMR/L4002-CG05	4	26.7	4.0	0.2	5°	○		