

MOF 45° 面銑刀 45°FACE MILLING CUTTERS (MOF)

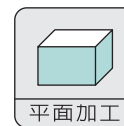
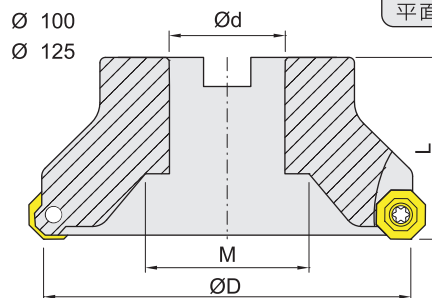
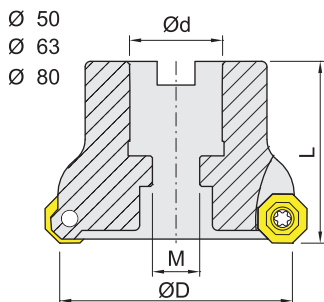

Metric

Item code	Dimensions,mm				Teeth	Insert	Screw	Wrench	Weight Kg
	D	d	L	M					
MOF0545R-05004-22.0	50	22.0	40	11	4	OFMT050405ER-SH	MS4011A	ETF15	0.41
MOF0545R-06305-22.0	63	22.0	40	11	5				0.61
MOF0545R-08006-27.0	80	27.0	50	13	6				1.18
MOF0545R-10007-32.0	100	32.0	50	45	7				1.51
MOF0545R-12508-40.0	125	40.0	63	55	8				2.61

Inch

Item code	Dimensions,mm				Teeth	Insert	Screw	Wrench	Weight Kg
	D	d	L	M					
MOF0545R-06305-25.4	63	25.4	50	13	5	OFMT050405ER-SH	MS4011A	ETF15	0.70
MOF0545R-08006-25.4	80	25.4	50	13	6				1.20
MOF0545R-10007-31.75	100	31.75	50	45	7				1.51
MOF0545R-12508-38.1	125	38.1	63	55	8				2.62
MOF0745R-10006-31.75	100	31.75	50	45	6	OFMT070405EN-SH	MS5011A	ETF20	1.51

被切削材 Workpiece material	Steel 鋼	P	●	
	Stainless steel 不銹鋼	M	●	
	Cast iron 鑄鐵	K		●
	Non-ferrous metal 非鐵金屬	N		

Insert Shape	Description	GRADE 材質		Dimensions,mm		
		Coated Carbide 硬質合金		A	S	Re
		PR830	PR1210			
	OFMT050405ER-SH	●		13.47	4.76	0.5
	OFMT070405EN-SH	●		17.98	4.87	0.5

內徑車刀
BORING BARS

外徑車刀
TOOLHOLDERS

牙刀 & 開槽刀
THREADING & GROOVING

銑刀
MILLING

孔加工
BORING TOOLS COMPONENTS

配件
SPARE PARTS